

Lag Driver
910206
Operating and Maintenance Manual



Lag Driver

910206

Record of Changes

Rev No.	Date	Description of Changes
Rev 1	4.2021	Initial release.
Rev 1.1	10.2023	Update Technical Support & Service information

Table of Contents

Section 1: Overview and Safety	5
Lag Driver Overview.....	5
Safety Information	5
Safety Terms	5
Machine Use and Safety Precautions	6
Personal Protective Equipment	7
Lag Driver Unpacking and Transport	7
Section 2: Specifications	8
Lad Driver Components.....	8
Specifications	9
Hydraulic Fluid	9
Section 3: Tool Operation	10
Installing the Socket	10
Functional Test	10
Operation	10
Loosening and Tightening of Lag Screws	10
Disconnecting the Hydraulic Hoses	11
Hose Requirements	13
Hose Types	13
Hydraulic Hose Recommendation	14
Tool Connecting Procedures	14
Disconnecting Hoses	15
Section 4: Maintenance.....	16
Troubleshooting.....	17
Section 5: Parts and Service Support	19
Service Parts	20
Manifold and Handle Assembly.....	21
Final Assembly	22
Hose and Coupling Assembly	23
Lag Driver Parts List	24

This page was intentionally left blank.

Section 1: Overview and Safety

Lag Driver Overview

Racine Railroad Products designs and manufactures equipment primarily for the repair and new construction of rail and railroad tie track maintenance.

The RRP Lag Driver is designed to install and remove a variety of lag bolt styles into ties from a standing position.

Rails are fastened to the sleepers with lag bolts and sleeper screws during rail mounting. Rail fastenings can be tightened or loosened with the Lag Driver.

Note: Bolts that must be tightened to a particular torque value cannot be tightened with the Lag Driver.

The Lag Driver will help eliminate the use of other methods that increase the likelihood of injury. When properly used, this tool helps reduce back strain and reduces operator fatigue.

Note: Information in this document is subject to change without notice.

Safety Information

For safe installation and operation of this equipment, carefully read and understand the contents of this manual. Improper operation, handling, or maintenance can result in equipment damage and personal injury.

Only trained and authorized personnel should be allowed to operate this machine. In addition, all personnel at the worksite (gang) should be aware of the safety concerns and their individual responsibilities prior to working with this machine.

Please read and comply with all the safety precautions in this manual **before** operating this machine. Your safety is at risk.

Safety Terms



DANGER indicates a hazardous operating procedure, practice, or condition. If the hazardous situation is not avoided death or serious injury will occur.



WARNING indicates a hazardous operating procedure, practice, or condition. If the hazardous situation is not avoided death or serious injury could occur.



CAUTION indicates a potentially hazardous operating procedure, practice, or condition. If the hazardous situation is not avoided moderate or minor injury could occur.



NOTICE: indicates an operating procedure, practice, or condition not related to personal injury.

Machine Use and Safety Precautions



Failure to follow safety precautions when operating this equipment can result in serious injury or death to the operator or other persons in the area.

Observe the following precautions whenever you are operating, working on or near this equipment.

Do not use this machine for other than its intended purpose.

Do not make any modifications without authorization or written approval from Racine Railroad Products. Replace all Racine Railroad Products and OEM parts with genuine Racine Railroad Products and OEM parts. Using non-OEM parts may compromise the safety of the machine.

Do not wear loose clothing, jewelry, radio belts, etc., when operating, working on or near this equipment. They can be caught in moving parts and may result in severe injury.

Always wear appropriate personal protective clothing when operating this equipment: e.g., Orange safety vest, hard hat, safety glasses with side shields, hearing protection, steel-toed safety boots, leather gloves, dust respirator, etc.

Always lift heavy objects with the knees and legs, not the arms and back.

Always keep hands, arms, feet, head, clothing, etc., out of the operating area and away from all rotating or moving components when operating, working on or near this machine.

Always make sure that all guards, covers, belts, hoses, and operating components are in good working order and that all controls are in the appropriate position before starting the engine.

Always make sure that all safety equipment installed properly and are in good working order. Do not operate the machine until unsafe conditions have been corrected.

Always operate in a well-ventilated area and make sure that the air filters, air filter covers, and muffler are in good condition.

Always keep the machine clean and free of debris. Operate the machine in a safe and responsible manner. Exercise caution when fueling, working on or near rotating or moving components, hot components, and fuel systems. Be aware of potential fire hazards and prevent sparks, exhaust, etc., from starting fires on the machine and/or work area.

Always comply with all instructions provided on any decals or placards installed on the machine and with any relevant amplifying information provided in this manual or other general operating procedures.

Always shut disconnect the power source and make sure that all controls are in a safe position and install all appropriate locking and safety devices before doing any of the following:

- Lubricating
- Adjusting
- Installing Tooling
- Making Repairs
- Performing Service

Personal Protective Equipment



Before operating this machine, make sure that all general safety precautions are observed, and that proper personal protective clothing is worn as described below.

At a minimum, operators should wear the following Personal Protective Equipment:

1. Safety Glasses
2. Hearing Protection
3. Safety Helmet
4. High Visibility Safety Vest
5. Leather Work Gloves
6. Steel Toed Safety Shoes

Lag Driver Unpacking and Transport

Upon receiving your Lag Driver promptly remove it from the shipping container. Always keep the top side of container up. Inspect unit for damage which may have incurred during shipping and report it to carrier for claim.

The Lag Driver is equipped with transport handles. Use the handles for transport.

Tool Preparations

If the Lag Driver is used in cold weather, preheat the hydraulic fluid by running the power source at low engine speed.

Fluid temperature should be at or above 50° F/10° C (400-ssu / 82 centistroke) before use, when using recommended fluids. Using too thick of fluid may result in tool damage.



WARNING

Never stick foreign objects, fingers, or other extremities into the moving mechanism. Failure to follow these instructions may lead to severe personal injury or tool damage.

Transporting the Lag Driver

The machine must be disconnected from the hydraulic unit for transport. The hydraulic unit must be switched off and the system depressurized. Once depressurized the hydraulic hose couplings can be detached. The machine can be transported fully assembled.

Section 2: Specifications

Lad Driver Components

1. Trigger
2. Trigger Lock
3. Rotation Button (forward / reverse)
4. Insulated handle to reduce vibration and operator fatigue
5. Hydraulic Hose
6. Socket (not shown)



Specifications

Width	5 inch / 127 mm
Length	16.50 inch / 419 mm
Height	29 inch / 737 mm
Weight	40 lbs / 18 kg
Hydraulic Pressure	max. 2,150 psi / 150 bar
Hydraulic Flow	max. 10 gpm / 40 lpm
Max Torque	2,800 ft-lbs / 3,796 Nm
Socket Dimension	1 inch / 2.54 cm

The machine is designed for use on construction sites outdoors at temperatures between -20 °C to 45 °C (-4°F to 113°F). The temperature of the hydraulic fluid should be at least 10 °C (50°F).

The statutory minimum distance must be observed around power lines and conductor rails.

Hydraulic Fluid

The hydraulic fluid should meet the following requirements.

Viscosity (at 10 °C)	95 cSt
Viscosity (at 38 °C)	27-42 cSt
Viscosity (at 60 °C)	16,5 cSt
Pour point	-10 °C
Viscosity index (ASTM-D2220)	min. 140
Flash point (ASTM-D92)	min. 171 °C
Pump wear test (ASTM-D2882)	max. 60 mg
Demulsibility (ASTM-D1401)	max. 30 minutes

The following hydraulic fluids or equivalent are suitable for use.

Manufacturer	Type
Chevron	Clarity AW ISO 32
Mobil	Univis J32
Gulf	Harmony AW-HVI-150-32
Shell	Tellus T32

Section 3: Tool Operation

Installing the Socket

1. Remove the retaining ring.
2. Align the hole in the socket with the hole in the 1" drive and install the socket onto the drive.
3. Insert the retaining pin through the holes to secure the socket to the 1" drive.
4. Reinstall the retaining ring.



Socket Retaining Ring



Retaining Pin

Functional Test

Proceed with the following steps to check the function of the Lag Driver:

1. Connect the Lag Driver to the hydraulic unit.
2. Switch the hydraulic unit on.
3. Safely hold the Lag Driver off the ground, holding it with both hands.
4. Pull the operating lever.
 - The socket must turn.
5. Release the operating lever.
 - The socket must stop.
6. Press the rotation button to change the socket rotation and test again.
 - Only press the rotation button when the Lag Drive is not in operation (rotating).

Operation

Visually inspect the area before beginning work. Do not start work if damage to the Lag Drive is visible.

Install hydraulic hoses away from walking and transport routes. Make sure the hydraulic hoses are not installed over sharp edges.

Loosening and Tightening of Lag Screws

Note: Use only sockets designed to drive the style of lag screw being used.

1. Mount the socket on the Lag Driver.
2. Clean the quick couplings.
3. Connect the Lag Driver to the return flow of the hydraulic unit.
4. Connect the Lag Driver to the flow of the hydraulic unit.
 - Make sure the flow and return flow of the hydraulic unit are connected to the right quick couplings on the Lag Driver.
5. Start the hydraulic unit.
6. Set the correct rotation direction.
7. Position the socket end over the lag to be installed or removed.

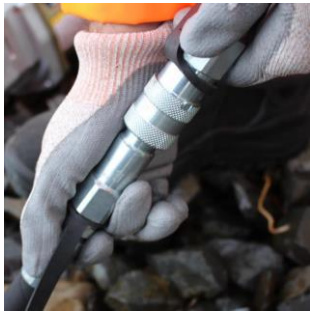

Hydraulic Connection to
Return Flow of Hydraulic Unit



Hydraulic Connection to
Flow of Hydraulic Unit

8. Loosen the trigger lock and press the operating lever on the handle.
 - Make sure the screw is not stripped when tightening.
9. Let go of the trigger on the Lag Driver after tightening or loosening the bolt.
10. Lift the Lag Driver off the rail.



Lag Driver Trigger and Trigger Lock

Disconnecting the Hydraulic Hoses

1. Stop the hydraulic power source.
2. Depressurize the system.
3. Allow system and hydraulic fluid to cool.
4. Disconnect the supply (pressure) hose from the power source (pressure port) from the tool (IN port).
5. Disconnect the return (tank) hose to the hydraulic power source (return port) from the tool (OUT port).
6. To prevent contamination, always install dust caps over the hydraulic ports of the tool when disconnected.



If injury results from escaping hydraulic fluid, seek immediate medical attention. Serious bodily injury may occur if proper medical attention is not administered immediately.

Do not attempt to locate hydraulic leaks by feeling around hoses and fittings with your hands. Pinhole leaks can penetrate the skin.

Note:

- When the lag contacts the surface of the material being fastened, limit impact time to 10 seconds.
- Excessive wear will occur to the hammer mechanism due to the heat buildup.
- When removing a lag, run the lag driver until the lag is clear of the hole.
- Remove the driver from the lag a move on to the next lag.

Hose Requirements

It is not often necessary or advisable to use long hoses. All hoses must have an oil resistant inner surface and an abrasion resistant outer surface. Each hose must have male pipe ends for most application.

Longer hoses can be used when necessary but can affect the operation of the tool due to resistance in the hose.

If small diameter or long hoses are used, or if restrictive fittings are connected to the supply and return ports, the pressure required to push the fluid through the system and back to the tank will be higher. This will reduce tool power.

Important: Oil should always flow from the male coupler through the female coupler.

Note: The pressure increases in uncoupled hoses left in the sun. This may make them difficult for them to connect. When possible after use, connect the free ends of the operating hoses together.

Hose Types

Inspect hoses for cuts, crushing, leaks, or abrasion, which may be a safety hazard or reduce fluid flows.

Hydraulic hose types authorized for use with the Lag Driver are:

1. **Labeled and certified non-conductive.**

- This is the only hose authorized for use near electrical conductors.
- Constructed of thermoplastic or synthetic rubber inner tube, synthetic fiber braid reinforcement, and weather resistant thermoplastic or synthetic rubber cover.

2. **Wire braided** (conductive)

- This hose is conductive and must **never** be used near electrical conductors.
- Constructed of synthetic rubber inner tube, single or double wire braid reinforcement, and weather resistant synthetic rubber cover

3. **Fiber braided** (not certified or labeled non-conductive)

- This hose is conductive and must **never** be used near electrical conductors.
- Constructed of thermoplastic or synthetic rubber inner tube, synthetic fiber braid reinforcement, and weather resistant thermoplastic or synthetic rubber cover.

The rated working pressure of the hydraulic hose must be at least 175 bar (2500 psi).

Hydraulic Hose Recommendation

Hydraulic Hose Recommendation								
Flow Per Circuit		Length Each Hose		Use	Inside Diameter		SAE Spec Hose (Wire Braid)	SAE Spec Hose (Fiber Braid)
GPM	LPM	Feet	Meter		Inch	MM		
5 to 8	19 to 30	To 50	To 15	Both	1/2	13	SAE 100R1-8	100R7-8
5 to 8	19 to 30	51 to 100	15 to 30	Both	5/8	16	SAE 100R2-10	SAE 100R8-10
5 to 8	19 to 30	100 to 300	30 to 90	Pressure Return	5/8 3/4	16 19	SAE 100R2-10 SAE 100R1-12	SAE 100R8-10 SAE 100R7-12
9 to 12	34 to 45	To 50	To 15	Both	5/8	16	SAE 100R2-10	SAE 100R8-10
9 v 12	34 to 45	51 to 100	15 to 30	Pressure Return	5/8 3/4	16 19	SAE 100R2-10 SAE 100R3-12	SAE 100R8-10 SAE 100R7-12
9 to 12	24 to 45	100 to 200	30 to 60	Pressure Return	3/4 1	19 25.4	SAE 100R2-12 SAE 100R1-16	SAE 100R8-12 SAE100R7-16

The rated working pressure of the hydraulic hose must be at least 2500 psi / 173 bar.

Tool Connecting Procedures

1. Stop the engine before connecting the tool and or hoses to the OFF power unit, and when switching hoses or tools.
2. Turn the hydraulic on/off valve to the off position before starting the engine.

Make sure all hoses are connected for correct flow direction to and from the tool being used.

When routing hose in the work area, position them where personnel will not be at risk of tripping over them where vehicles can run over the hoses. Do not lay hose over sharp objects.



WARNING Pressurized fluid escaping from a damaged hose can penetrate the skin and be injected in the body causing injury or death.

Do not pull on hoses to drag the power unit or tool.

Connecting Hoses

1. Wipe quick couplers with a clean lint free cloth before connecting them.
2. Depressurize the system.
3. Allow system and hydraulic fluid to cool if too hot to handle.
4. Securely connect the return (tank “R”) hose from the power source to the tool.
5. Securely connect the supply (pressure “P”) hose from the power source to the tool.

It is recommended that you connect the return hoses first and disconnect last to minimize or avoid trapping pressure within the tool.

When connecting the quick couplers, the flow should run from male coupler to the female coupler. The female coupler on the tool is the inlet. Quick couplers are marked with a flow direction arrow.

**WARNING**

Pressurized fluid escaping from a damaged hose can penetrate the skin and be injected in the body causing injury or death.

Do not pull on hoses to drag the power unit or tool.

Note: When possible, connect the free ends of uncoupled hoses to prevent build up in the hoses. The sun can also increase pressure in the hoses and make connecting them difficult.

1. Grip the handles firmly with both hands.
2. Pull down with thumb on the safety lock and pull the trigger to the handle to start the driver.
3. When starting the tool, hold it off from all surfaces.
4. When finished, release the trigger, and make sure trigger is in the locked position before placing the tool on any surface.

Disconnecting Hoses

1. Stop the hydraulic power source.
2. Depressurize the system.
3. Allow system and hydraulic fluid to cool.
4. Disconnect the supply (pressure) hose from the power source (pressure port) from the tool (IN port).
5. Disconnect the return (tank) hose to the hydraulic power source (return port) from the tool (OUT port).
6. To prevent contamination, always install dust caps over the hydraulic ports of the tool when disconnected.

Section 4: Maintenance

It is highly recommended to practice regular check-ups and maintenance in accordance with the usage frequency to keep your tool in better condition and reduces total running costs.



WARNING

Do not perform maintenance on the Lad Driver while the hydraulic power source motor is running or when hoses are connected.

All maintenance must be done with the tool disconnected from power source.

Cleaning and Maintenance Recommendations

- Wipe all external surfaces after each use with a clean, lint free cloth to remove surface contaminants from the tool.
- To extend the life of the handle padding, do not allow sharp edges or foreign objects to rub on the padding.
- Store all tools in an enclosed area to prevent the weather from contaminating their systems.

When maintenance is complete, make sure the following:

- The hydraulic control valves are operable.
- The hydraulic quick couplers and hoses are safe to use.

Daily



WARNING

Do not attempt to locate hydraulic leaks by feeling around hoses and fitting with hand. Pin-Hole leaks can penetrate the skin.

- Wipe all tool surfaces, fittings, and couplings free of grease, dirt, and foreign materials.
- Inspect the tool, hydraulic system, hoses, and fittings for signs of leaks, cracks, wear, and/or damage. Replace if necessary.
- To prevent contamination, always install dust caps over the hydraulic ports when disconnected.

Weekly Maintenance

Grease the Lag Driver using the grease zerk located on top of the motor adapter plate.

Apply 2 to 3 strokes (approximately 4 cc's) from a standard grease gun using appropriate grease.

- Grease leakage from around the square drive is common after lubrication and during hard use. Wipe the grease off to prevent it from splattering all over.

Note: Do not attempt to repair this product. Only properly trained personnel should perform any maintenance service, and or repair this tool.

Monthly Maintenance

- Perform a detailed inspection of the systems hoses, and fittings according to the hydraulic hose operator's manual and as stated in SAE standard j1273, May 1989 or latest revision.
- Replace the hoses and/or fittings if necessary.

Change of Hydraulic Fluid

The hydraulic fluid must be replaced annually. Depending on usage and contamination, the hydraulic fluid may need to be replaced at shorter intervals.

Old hydraulic fluid must be disposed of properly. Refilling must be carried out via the hydraulic unit. The hydraulic unit is not contained in the scope of service of the machine. Old hydraulic fluid must be disposed of properly.

Cold Weather Operation

Hydraulic fluids are thicker in cold weather; therefore, run the engine at low idle long enough to bring the fluid temperature up to minimum of 50° F / 10° C or until the top of the hydraulic tank feels warm, before operating tool.

Storage Preparation

The tool should be stored in a cool, dry environment which is not subjected to rapid temperature changes.

- Cover male and female hose whips.
- Store in the upright position.
- Secure tool to prevent it from being knocked over.
- Store the Lag Driver on a smooth level surface.

Troubleshooting

The following chart can be used as a guide to correct any problem you may experience with the tool.

To determine the problem in operation of the lag driver always check that the hydraulic power source is supplying the correct hydraulic flow and pressure to the tool as listed in the table. Be sure you are using an accurate flow meter. Check the flow with the hydraulic fluid temperature at least 80° F / 27° C.

Note: Stop and depressurize the hydraulic system before connecting or disconnecting a tool.

Failure to follow these instructions can lead to severe personal injury. Read and follow the instructions in this manual for the proper way to connect and disconnect tools from the hydraulic systems.

Problem	Cause	Remedy
Tool will not run or runs slow.	Power source.	Check power source flows and pressure (5-10 GPM/20-38 LPM at 1500-2000 psi/100-140 bar).
	Coupler or hose.	Check for /remove obstruction.
	Directional spool not fully shifted.	Shift spool to either position.
	Mechanical failure.	Disassemble tool and check for damage.

Troubleshooting Continued

Problem	Cause	Remedy
Poor impact performance.	Pressure and return hoses reversed.	Correct for proper flow direction.
	Worn impact components.	Disassemble front half of impact and check for damaged or severely worn parts.
	Incorrect grease.	Remove and clean impact head.
	Screw head greasy.	Remove grease from screw heads
	Unsuitable socket or adapter.	Check the components used and replace if necessary.
	Cold hydraulic fluid.	Allow power source to warm up
Trigger hard to pull.	Back pressure too high.	Should not be exceed 250 psi / 17 bar and 10 gpm / 38 Lpm.
	Control Linkage.	Inspect the linkage between trigger and valve spool.
Hydraulic fluid leaks between motor and manifold block.	Damaged seal.	Disassemble tool and replace seal.
Hydraulic fluid leaks between adapter and motor.	Damaged shaft seal.	Split tool between adapter and motor and replace seal.
Hydraulic fluid leaks from control spools.	Damaged seals.	Replace all O-rings and backups on leaking spool.
Grease leaks between impact head and adapter.	Loose Fasteners.	Tighten bolts.
Grease leaks around impact drive shaft.	Heavy duty use.	Normal due to heat build-up.
	Impact Mechanism over-greased.	Wipe clean until grease stops leaking, adjust greasing maintenance to match duty cycle.
Grease leaks around impact drive shaft when cold.	Anvil bushing worn.	Replace anvil bushing.

Section 5: Parts and Service Support

Technical Support & Service

Telephone and web-based technical support is available for current production models through our Customer Service Department. Service Manuals and limited technical support may be available for models that are no longer in production.

Telephone and E-mail Technical Support

Telephone and e-mail technical support is available on normal U.S. business days from 8:00 AM to 5:00 PM U.S. Central Time Zone (GMT +6 (+5 Daylight Savings Time)).

Phone: (262) 637-9681

Email: custserv@racinerailroad.com

Racine Railroad Products
1955 Norwood Court
Mount Pleasant, WI 53403

Non-Warranty Technical Support

Depending upon the circumstances and availability of technical service personnel, we may provide technical assistance and/or field service support, *at the customer's expense*, to assist in the correction of non-warranty related problems. Contact our Customer Service Department to coordinate Non-Warranty Technical or Field Service Support.

Warranty Support Technical Support

Depending upon the circumstances and availability of technical service personnel, we may provide technical assistance and/or field service support, *at no charge to the customer*, to assist in the correction of warranty related problems. Contact our Customer Service Department to coordinate Warranty Technical or Field Service Support.

Warranty Parts Claims

Material claimed to be defective must be returned to our factory for evaluation. Defective materials will be replaced, or your account will be credited if replacement materials have already been purchased. Please contact our Customer Service Department at the address provided below if you have any questions or problems.

Warranty Service Support

Depending upon the circumstances and availability of technical service personnel, we may provide technical assistance and/or field service support, at no charge to the customer, to assist in the correction of warranty related problems. Contact our Customer Service Department at the address provided above to coordinate Warranty Service Support.

Non-Warranty Parts Orders

When placing a parts order please provide the following information:

- Company Name and Billing Address
- Purchase Order Number and Issuing Authority
- Shipping Address
- Special Handling Instructions
- Contact Phone Number
- Machine Model and Serial Number
- Part Numbers and Quantities Being Ordered

Note: *Please use Racine Railroad Products part numbers when ordering parts.* Racine Railroad Products part numbers are shown in the parts lists and drawings of this manual and have only six (6) numbers.

Any part number with other than six numbers (e.g., contains alpha-numeric characters) is a Vendor Part Number and **not** a Racine Railroad Products part number

Service Parts

FOR SERVICE ONLY

DESCRIPTION	PART NO.
BAR, HANDLE	475629
COVER, COUPLER	471450
MOTOR, HYDRAULIC	466611
SPLINE, COUPLER	466177
WIPER	466172

Manifold and Handle Assembly

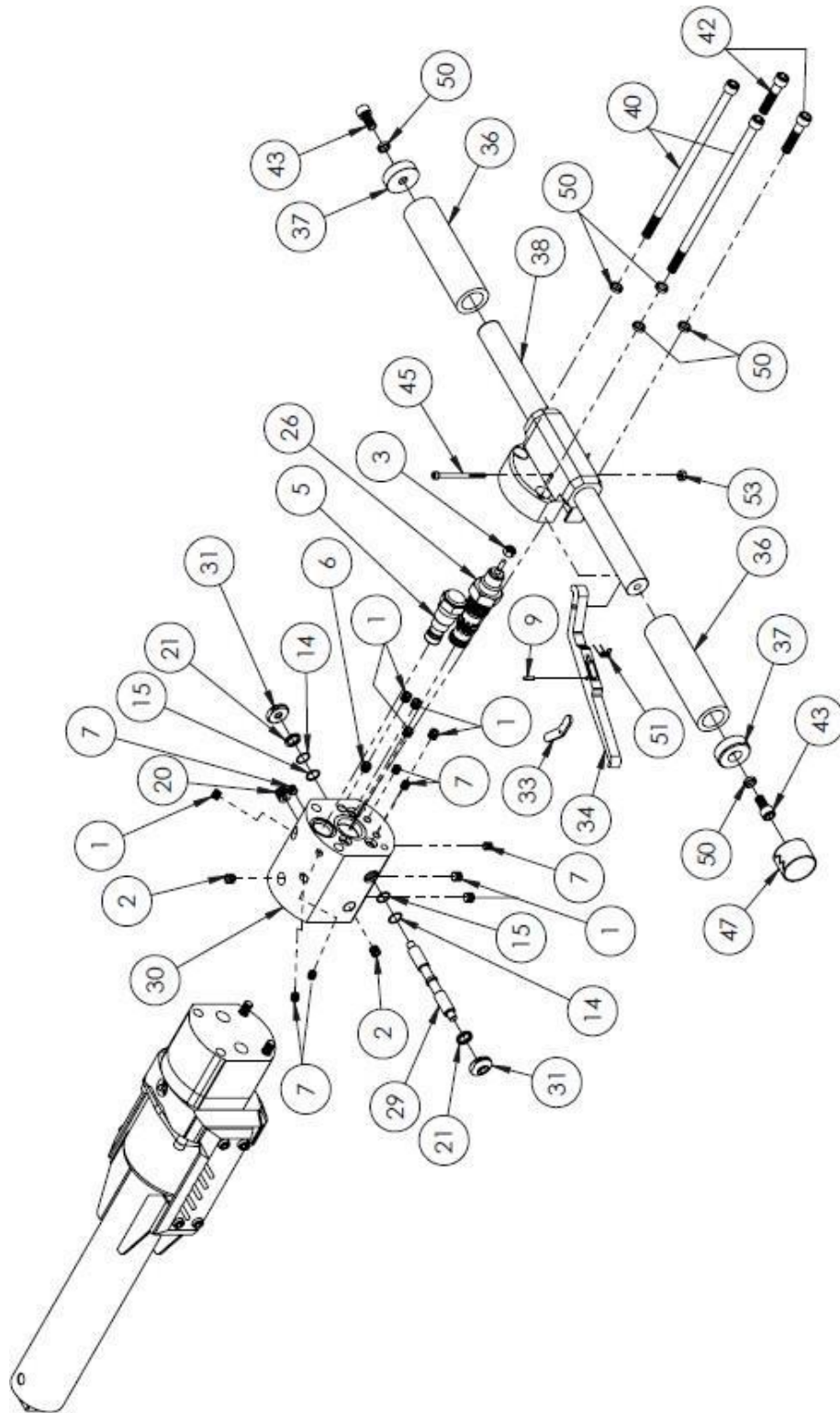

Final Assembly

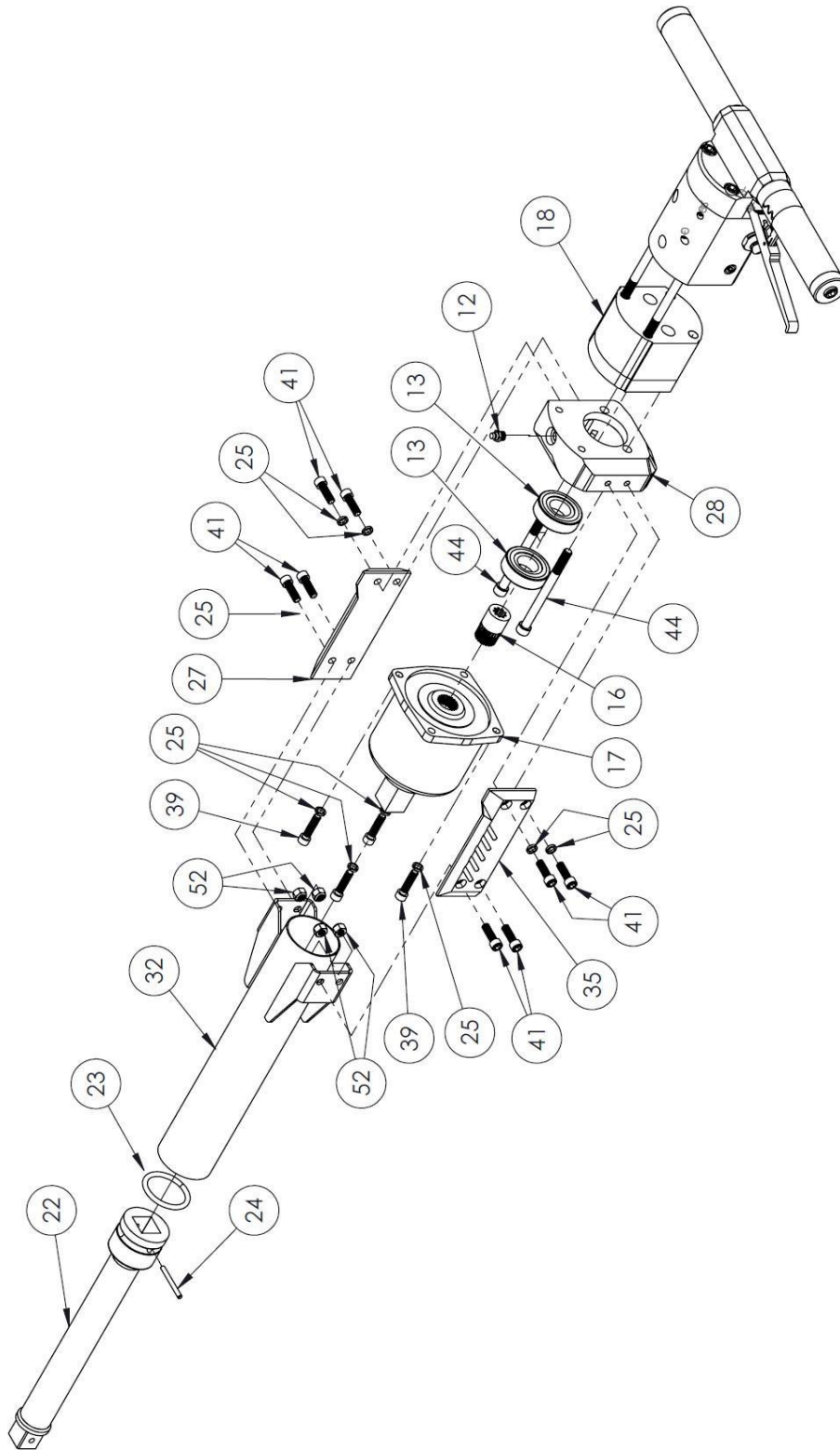

Hose and Coupling Assembly

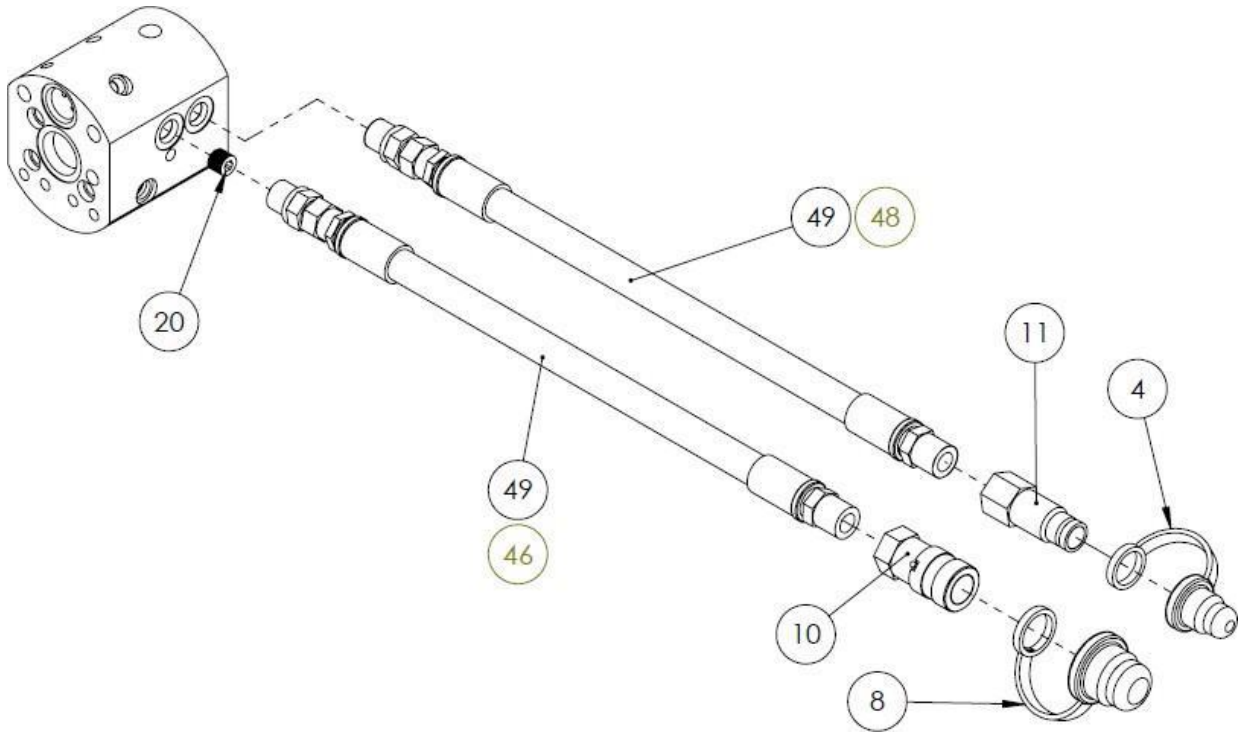

Lag Driver Parts List

Part #.	Description	Qty
1	PLUG, 1/8MNPT	7
2	PLUG, 1/4MNPT	2
3	NUT, 1/4-20	1
4	COVER, M COUPLER	1
5	VALVE	1
6	ORIFICE, .024 DIA	1
7	PLUG, 1/16 MNPT	6
8	COVER, FM COUPLER	1
9	PIN, 1/8 X 1/2 ROLL	1
10	COUPLER, 3/8FM	1
11	COUPLER, 3/8M	1
12	ZERK, 1/8 GREASE	2
13	BEARING,	2
14	O-RING BACK UP	2
15	QUAD RING	2
16	COUPLER SPLINE	1
17	HEAD, IMPACT	1
18	MOTOR HYD.	1
19	GRAPHIC SET COMP.	1
20	ORIFICE .218	1
21	SEAL, WIPER	2
22	1" DRIVE EXTENSION 13"	1
23	O-RING SOCKET RETAINING	1
24	PIN SOCKET RETAINING	1
25	WASHERS LOCK 5/16 HICOLLAR	8
26	CONTROL VALVE	1
27	CONNECTOR, GUARD RIGHT	1

Part #.	Description	Qty
28	ADAPTER, MOTOR	1
29	SPOOL, DIRECTIONAL	1
30	MANIFOLD, DL V2	1
31	CAP, SPOOL	2
32	GUARD, EXTENSION	1
33	STOP, TRIGGER	1
34	TRIGGER	1
35	CONNECTOR, GUARD LEFT	1
36	GRIP HANDLE	2
37	CAP, HANDLE	2
38	HANDLE BAR ASSEMBLY	1
39	BOLT, 5/16-18 X 1.25 SHCS	4
40	BOLT, 3/8-16 X 8.75 SHCS	2
41	BOLT, 5/16-18 X 1.00 SHCS	8
42	BOLT, 3/8-16 X 1.75 SHCS	2
43	BOLT, 3/8-16 X .75 SHCS	2
44	BOLT, 3/8-16 X 4.50 SHCS	2
45	BOLT, 10-24 X 2-1/2 SHCS S/S	1
46	HOSE, 1/2" X 18" – 8-8MP-8-6FJ W/ 202702-6-6 FITTING -AEROQUIP	1
47	BUSHING, SPRING	1
48	HOSE, 1/2" X 18" ASSEMBLY – AEROQUIP	1
49	HOSE, 1/2 X 18"	2
50	WASHER, LOCK 3/8 HIGH COLLAR	6
51	SPRING, DOUBLE TORSION	1
52	NUT, 5/16-18 NE ZP NYLOCK	4
53	NUT, 10-24 NYLOCK SS	1